

Peiner SK 415-20

TOWER CRANE

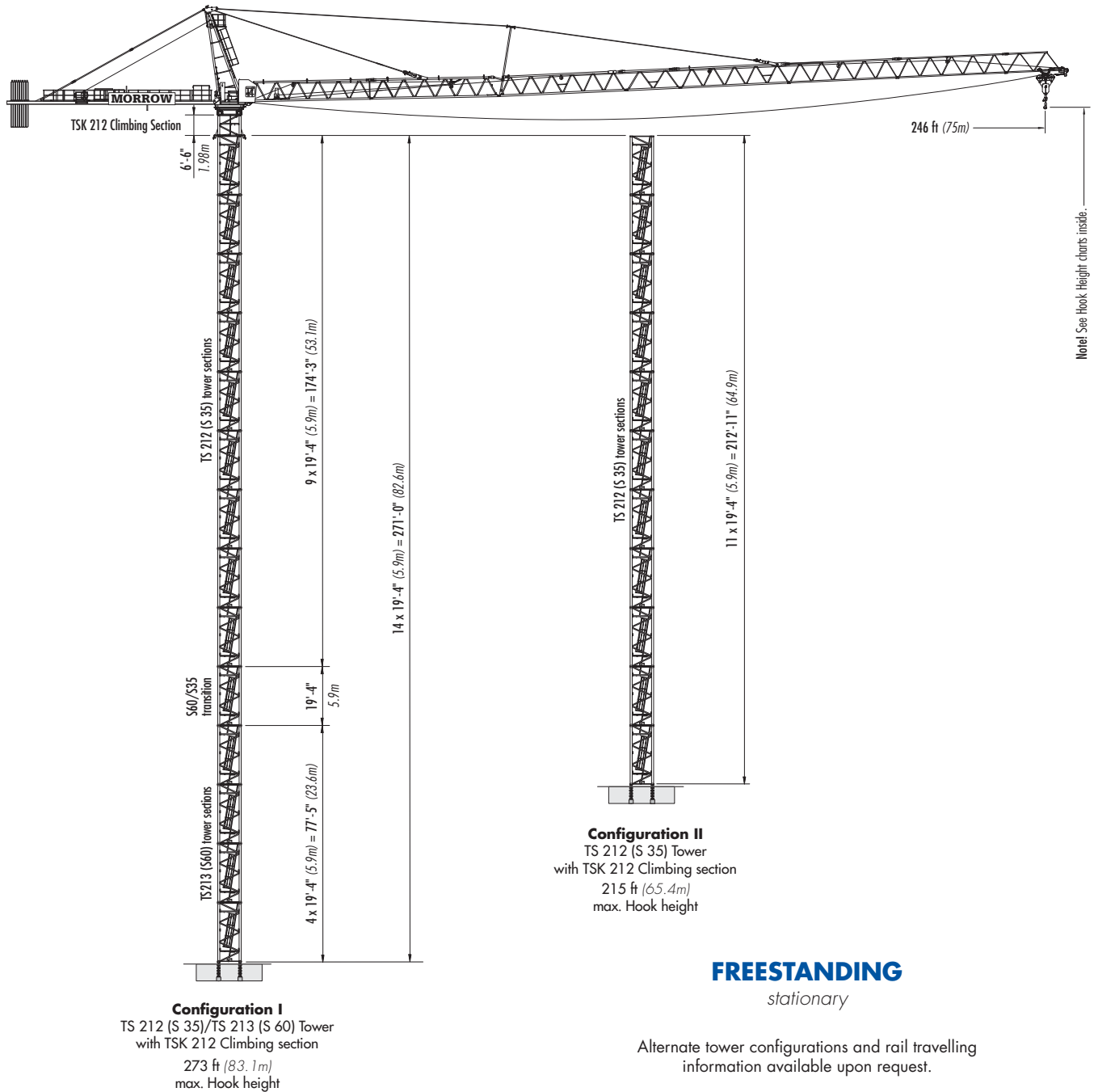

Peiner SK 415-20

Jib Layout

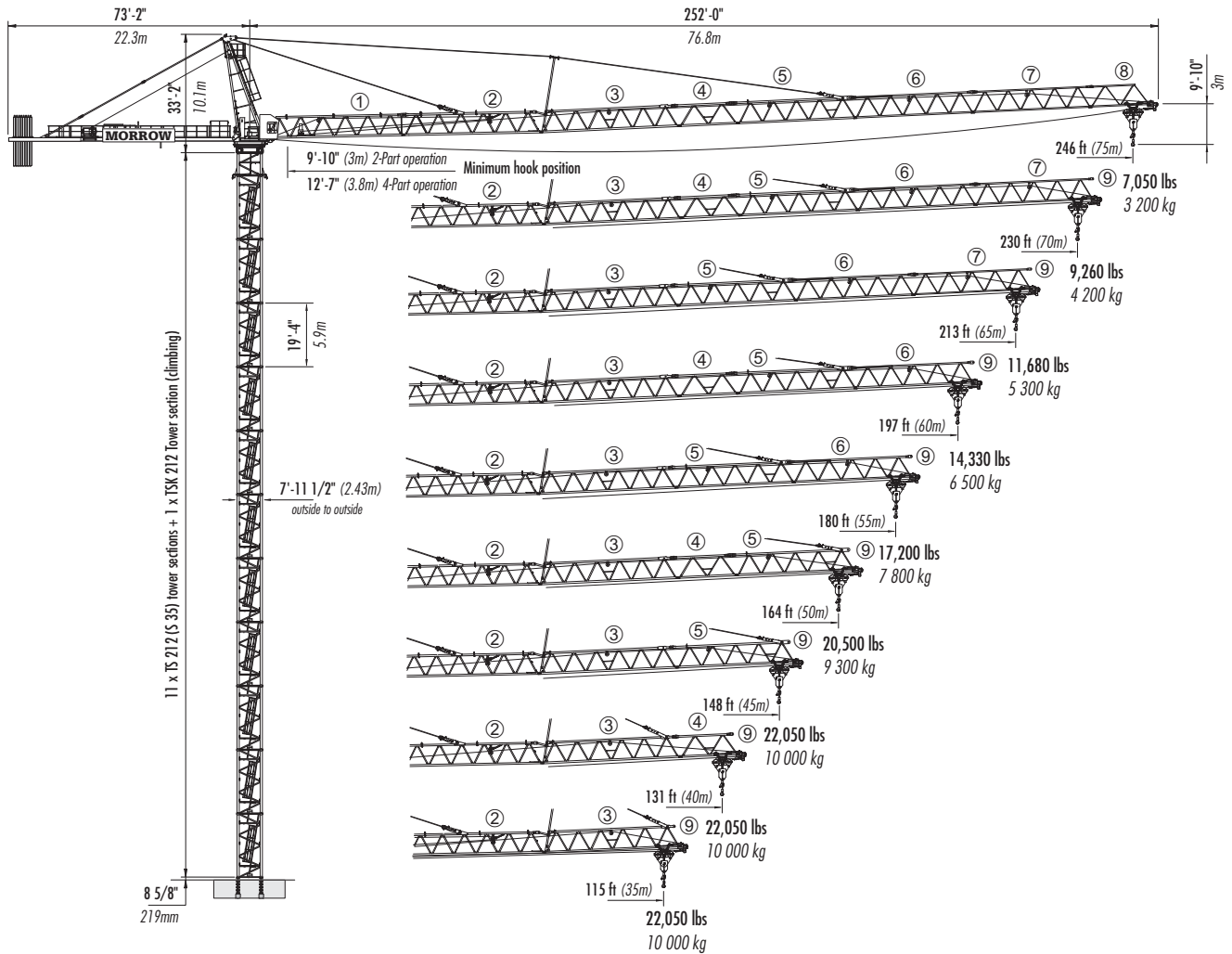

Counterweights

246-ft Jib	230-ft Jib	213-ft Jib	197-ft Jib	180-ft Jib	164-ft Jib	148-ft Jib	131-ft Jib	115-ft Jib
8 A	8 A	8 A	8 A	7 A	7 A	7 A	6 A	6 A
54,675 lbs	54,675 lbs	54,675 lbs	54,675 lbs	47,840 lbs	47,840 lbs	47,840 lbs	41,000 lbs	41,000 lbs
24 800 kg	24 800 kg	24 800 kg	24 800 kg	21 700 kg	21 700 kg	21 700 kg	18 600 kg	18 600 kg

NOTE! Counterweight information above applies to both 2-part and 4-part operation. Weight of the A Block is 6,835 lbs (3,100 kg). Counterweights must be installed from rear to front, i.e. towards the tower. It is recommended that the weight of each counterweight be verified before installation. Counterweight figures displayed in the chart above are for crane with hoist unit SR WB 76 - 100/4F. If another hoist unit is installed, refer to the Terex-Peiner SK 415-20 Operation Manual or contact Morrow Equipment.

Peiner SK 415-20

Hook Heights

Configuration I ⁴			
SK 415 on TS 212 (S 35) and TS 213 (S 60) tower			
		static concrete footing ³	
No. of Tower Sections	Tower Section Type	feet	meters
1 ¹	TS213 (S60) TS	21	6.4
2 ¹	TS213 (S60) TS	40	12.3
3 ¹	TS213 (S60) TS	60	18.2
4 ¹	TS213 (S60) TS	79	24.1
5 ¹	S60/S35 transition	98	30
6 ¹	TS212 (S35) TS	118	35.9
7 ¹	TS212 (S35) TS	137	41.8
8 ¹	TS212 (S35) TS	156	47.7
9 ¹	TS212 (S35) TS	176	53.6
10 ¹	TS212 (S35) TS	195	59.5
11 ¹	TS212 (S35) TS	215	65.4
12 ¹	TS212 (S35) TS	234	71.3
13 ^{1,2}	TS212 (S35) TS	253	77.2
14 ^{1,2}	TS212 (S35) TS	273	83.1

Configuration II ⁴			
SK 415 on TS 212 (S 35) tower			
		static concrete footing ³	
No. of Tower Sections	Tower Section Type	feet	meters
1 ¹	TS212 (S35) TS	21	6.4
2 ¹	TS212 (S35) TS	40	12.3
3 ¹	TS212 (S35) TS	60	18.2
4 ¹	TS212 (S35) TS	79	24.1
5 ¹	TS212 (S35) TS	98	30
6 ¹	TS212 (S35) TS	118	35.9
7 ¹	TS212 (S35) TS	137	41.8
8 ¹	TS212 (S35) TS	156	47.7
9 ¹	TS212 (S35) TS	176	53.6
10 ¹	TS212 (S35) TS	195	59.5
11 ^{1,2}	TS212 (S35) TS	215	65.4

NOTE!

¹ Includes TSK 212 climbing section which **MUST** be installed for any top climbing application. Hook heights are reduced by 6'-6" (1.98m) if TSK 212 is not installed.

² Lower top climbing unit to base of tower prior to operating crane.

³ Hook heights for cross base and railtravelling crane configurations available upon request.

⁴ Manufacturer tower configurations based on FEM 1.001 standard with maximum OOS wind speed of 94 mph (151 km/h).

Alternate tower combinations are possible. Refer to Operation manual or contact Morrow for information.

Consult crane Operation Manual before erecting, operating, servicing or dismantling crane.

Foundation Details *on concrete footing*

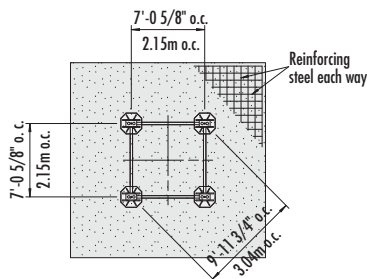
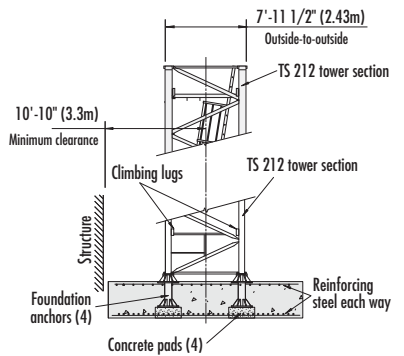

with TS 212 (S 35) Tower

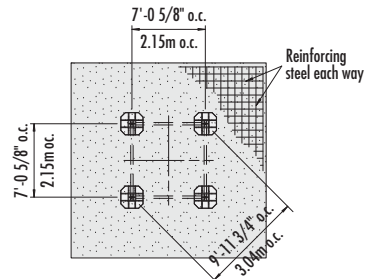
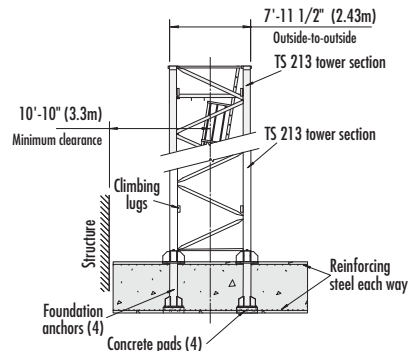

with TS 213 (S 60) Tower

Peiner SK 415-20

Radius and Capacities

2-Part Operation	Hook Radius	Jib Tip Radius	Maximum Capacity – Radius	ft	33	49	66	82	98	115	131	148	164	180	197	213	230	246	
				m	10	15	20	25	30	35	40	45	50	55	60	65	70	75	
	246 ft 75m	252'-0" 76.8m	22,050 lbs – 104 ft 10 000 kg – 31.6m	lbs kg	22,050 10 000	22,050 10 000	22,050 10 000	22,050 10 000	22,050 10 000	19,670 8 920	16,670 7 560	14,370 6 520	12,540 5 690	11,050 5 010	9,790 4 440	8,730 3 960	7,830 3 550	7,050 3 200	
	230 ft 70m	235'-7" 71.8m	22,050 lbs – 117 ft 10 000 kg – 35.6m	lbs kg	22,050 10 000	22,050 10 000	22,050 10 000	22,050 10 000	22,050 10 000	22,050 10 000	19,180 8 700	16,600 7 530	14,530 6 590	12,850 5 830	11,460 5 200	10,270 4 660	9,260 4 200		
	213 ft 65m	219'-2" 66.8m	22,050 lbs – 129 ft 10 000 kg – 39.2m	lbs kg	22,050 10 000	22,050 10 000	22,050 10 000	22,050 10 000	22,050 10 000	22,050 10 000	21,500 9 750	18,650 8 460	16,380 7 430	14,530 6 590	12,990 5 890	11,680 5 300			
	197 ft 60m	202'-9" 61.7m	22,050 lbs – 139 ft 10 000 kg – 42.4m	lbs kg	22,050 10 000	22,050 10 000	22,050 10 000	22,050 10 000	22,050 10 000	22,050 10 000	22,050 10 000	20,460 9 280	17,990 8 160	16,000 7 260	14,330 6 500				
	180 ft 55m	186'-0" 56.7m	22,050 lbs – 148 ft 10 000 kg – 45m	lbs kg	22,050 10 000	22,050 10 000	22,050 10 000	22,050 10 000	22,050 10 000	22,050 10 000	22,050 10 000	21,910 9 940	19,310 8 760	17,200 7 800					
	164 ft 50m	169'-7" 51.7m	22,050 lbs – 155 ft 10 000 kg – 47.3m	lbs kg	22,050 10 000	22,050 10 000	22,050 10 000	22,050 10 000	22,050 10 000	22,050 10 000	22,050 10 000	22,050 10 000	22,050 10 000	20,500 9 300					
	148 ft 45m	153'-3" 46.7m	22,050 lbs – 148 ft 10 000 kg – 45m	lbs kg	22,050 10 000	22,050 10 000	22,050 10 000	22,050 10 000	22,050 10 000	22,050 10 000	22,050 10 000	22,050 10 000	22,050 10 000						
	131 ft 40m	136'-10" 41.7m	22,050 lbs – 131 ft 10 000 kg – 40m	lbs kg	22,050 10 000	22,050 10 000	22,050 10 000	22,050 10 000	22,050 10 000	22,050 10 000	22,050 10 000								
115 ft 35m	120'-5" 36.7m	22,050 lbs – 115 ft 10 000 kg – 35m	lbs kg	22,050 10 000	22,050 10 000	22,050 10 000	22,050 10 000	22,050 10 000	22,050 10 000										

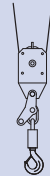

Capacity

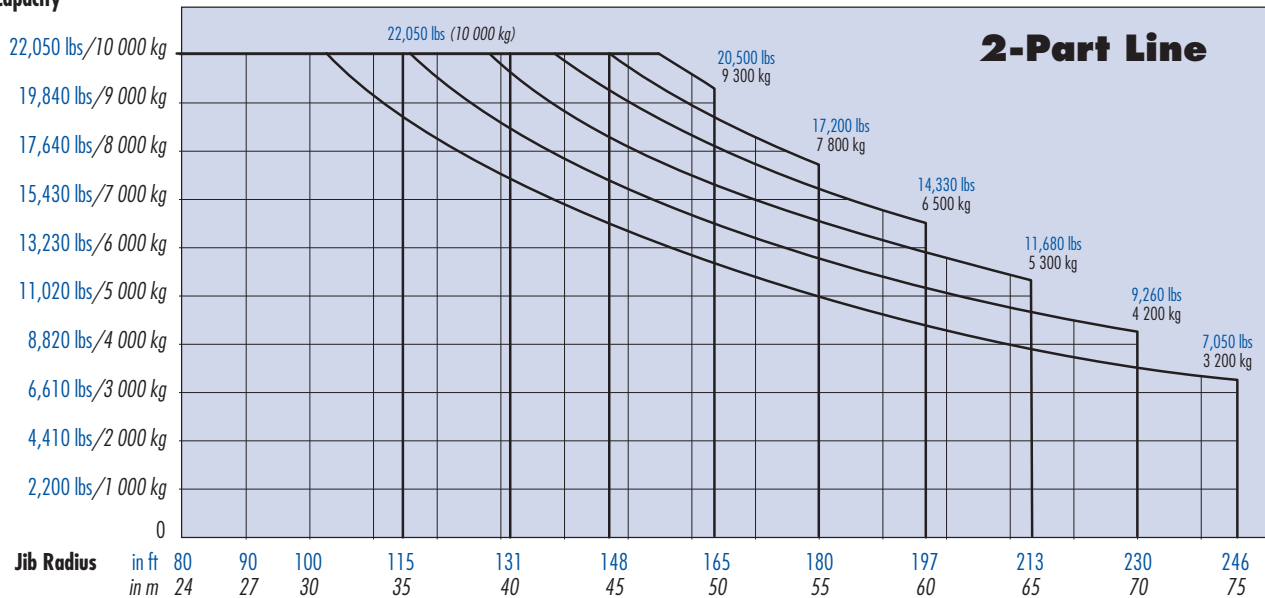

Peiner SK 415-20

Radius and Capacities

4-Part Operation	Hook Radius	Jib Tip Radius	Maximum Capacity – Radius	ft m	33 10	49 15	66 20	82 25	98 30	112 34	128 39	144 44	161 49	177 54	194 59	210 64	226 69	243 74
	243 ft 74m	252'-0" 76.8m	44,090 lbs – 58 ft 20 000 kg – 17.6m	lbs kg	44,090 20 000	44,090 20 000	37,480 17 000	28,400 12 880	22,530 10 220	19,110 8 670	15,850 7 190	13,360 6 060	11,380 5 160	9,770 4 430	8,420 3 820	7,300 3 310	6,350 2 880	5,510 2 500
	226 ft 69m	235'-7" 71.8m	44,090 lbs – 64 ft 20 000 kg – 19.4m	lbs kg	44,090 20 000	44,090 20 000	42,390 19 230	32,280 14 640	25,750 11 680	21,960 9 960	18,320 8 310	15,520 7 040	13,320 6 040	11,530 5 230	10,030 4 550	8,770 3 980	7,720 3 500	
	210 ft 64m	219'-2" 66.8m	44,090 lbs – 70 ft 20 000 kg – 21.2m	lbs kg	44,090 20 000	44,090 20 000	44,090 20 000	35,830 16 250	28,680 13 010	24,540 11 130	20,570 9 330	17,500 7 940	15,100 6 850	13,140 5 960	11,510 5 220	10,140 4 600		
	194 ft 59m	202'-9" 61.7m	44,090 lbs – 74 ft 20 000 kg – 22.7m	lbs kg	44,090 20 000	44,090 20 000	44,090 20 000	38,890 17 640	31,240 14 170	26,760 12 140	22,510 10 210	19,220 8 720	16,640 7 550	14,530 6 590	12,790 5 800			
	177 ft 54m	186'-0" 56.7m	44,090 lbs – 79 ft 20 000 kg – 24m	lbs kg	44,090 20 000	44,090 20 000	44,090 20 000	41,360 18 760	33,270 15 090	28,570 12 960	24,070 10 920	20,610 9 350	17,880 8 110	15,650 7 100				
	161 ft 49m	169'-7" 51.7m	44,090 lbs – 82 ft 20 000 kg – 25.1m	lbs kg	44,090 20 000	44,090 20 000	44,090 20 000	44,090 20 000	35,080 15 910	30,140 13 670	25,440 11 540	21,830 9 900	18,960 8 600					
	144 ft 44m	153'-3" 46.7m	44,090 lbs – 84 ft 20 000 kg – 25.6m	lbs kg	44,090 20 000	44,090 20 000	44,090 20 000	44,090 20 000	36,050 16 350	31,000 14 060	26,190 11 880	22,490 10 200						
	128 ft 39m	136'-10" 41.7m	44,090 lbs – 85 ft 20 000 kg – 26m	lbs kg	44,090 20 000	44,090 20 000	44,090 20 000	44,090 20 000	36,680 16 640	31,370 14 320	26,680 12 100							
	112 ft 34m	120'-5" 36.7m	44,090 lbs – 86 ft 20 000 kg – 26.1m	lbs kg	44,090 20 000	44,090 20 000	44,090 20 000	44,090 20 000	36,880 16 730	31,750 14 400								

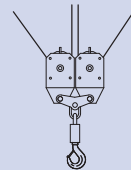

Capacity

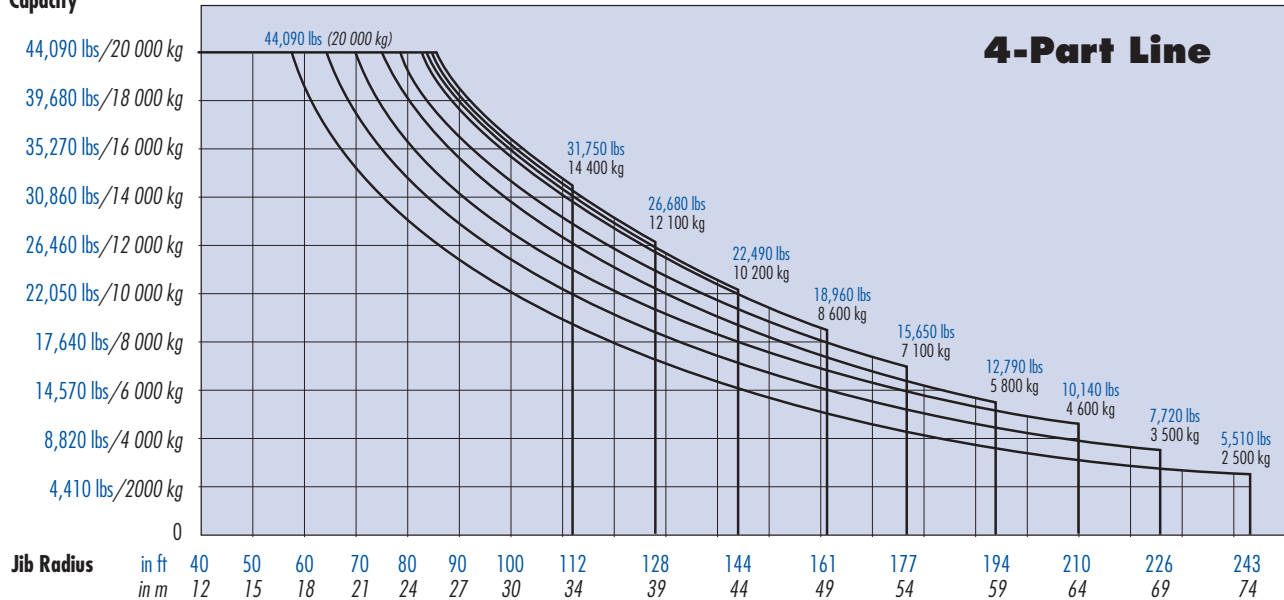

Peiner SK 415-20

Tie-in Details

NOTE! Recommended slab opening for erection and dismantlement. For other factors including deflection, contact Morrow engineering.

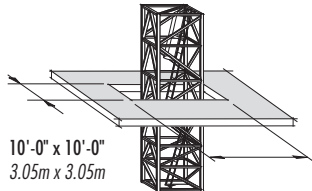

SLAB OPENING

Recommended
(TS 212/S 35)

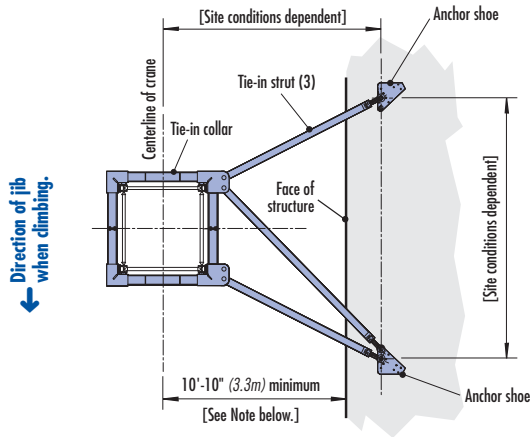

TIE-IN ASSEMBLY with TS 212 (S 35) Tower plan view

NOTE! The tie-in assembly shown is an example of a typical installation when using S 35 (TS 212) tower. Please note, however, that factors determining the installation of tie-in assemblies may vary due to project specific requirements. Contact Morrow for additional information.

Consult SK 415-20 Operation Manual before erecting, operating, servicing or dismantling crane.

NOTE! Restrictions apply; please consult operation manual or Morrow engineering.

¹ Lower top climbing unit to upper tie-in assembly prior to operating crane.

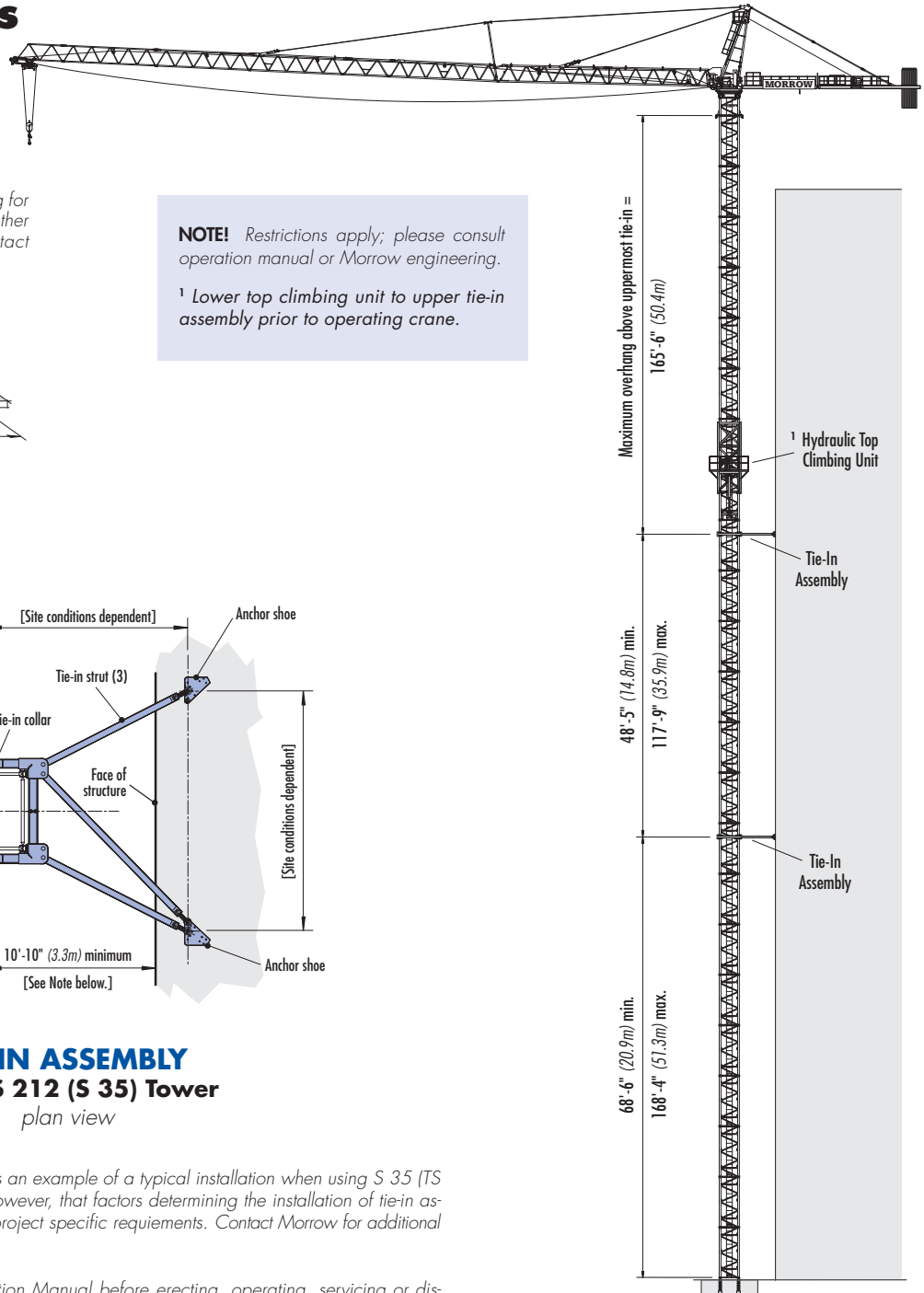

TOP CLIMBING with TS 212 (S 35) Tower tied to structure

Peiner SK 415-20

Hoist Speed and Capacity

Hoist Unit	SR WB 76 - 100/4F	2-Part Line			
108 hp (76 kW) AC hoist unit 4-speed gearbox Remote-controlled gear shifting Eddy current brake 2P5L250 4P5L125	Gear	Capacity	Line Speed	Capacity	Line Speed
	1	22,050 lbs @	112 fpm	10 000 kg @	34 m/min
	2	15,650 lbs @	177 fpm	7 100 kg @	54 m/min
	3	9,260 lbs @	276 fpm	4 200 kg @	84 m/min
	4	5,510 lbs @	440 fpm	2 500 kg @	134 m/min
	4-Part Line				
	1	44,090 lbs @	56 fpm	20 000 kg @	17 m/min
	2	31,300 lbs @	89 fpm	14 200 kg @	27 m/min
3	18,520 lbs @	138 fpm	8 400 kg @	42 m/min	
4	11,020 lbs @	220 fpm	5 000 kg @	67 m/min	

IMPORTANT! Capacities and line speeds indicated will vary depending on the amount of hoist rope installed. This crane model may be equipped with a hoist unit other than that specified in the data above. To verify, check the serial number of the crane and refer to the SK 415-20 Operation Manual for additional information.

Motor Information

Drive Unit	Horsepower	Kilowatts	Speed	
Trolley (VFD)	14 hp	10.5 kW	0 - 262 fpm	0 - 80m/min
Swing (VFD) *	3 x 11 hp	3 x 8.2 kW	1 rpm	
Travelling	Rail-travelling information available upon request.			











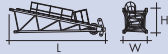
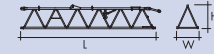

* **IMPORTANT!** Three (3) swing drives are required if 197-ft to 246-ft (60m to 75m) jib assembly is installed. Only two (2) swing drives are required if 115-ft to 180-ft (35m to 55m) jib assembly is installed. Refer to the SK 415-20 Operation Manual for additional information.

Power Requirements

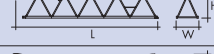
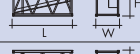
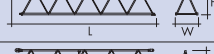
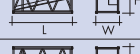
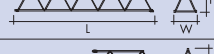
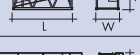
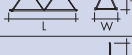
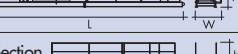
- 480 V phase-phase, 277 V each phase to ground with 120° phase shift between phases. Do not use an Open-Delta supply.
- 3-phase, 60 Hz power supply plus ground wire.
- Static: 250 Amperes
- Travelling: (Contact Morrow for power requirements.)

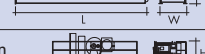
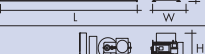
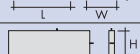
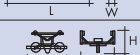
Specifications subject to change without prior notice. For additional information, contact Morrow Equipment.

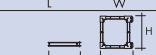
Peiner SK 415-20

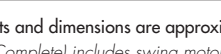
Description	Dimensions L x W x H	Weight	Description	Dimensions L x W x H	Weight
Tower Top (Complete) 	27'-1" x 6'-7" x 10'-2" 8.26m x 2m x 3.1m	9,610 lbs 4 360 kg	Jib Section ② 	40'-6" x 6'-7" x 7'-3" 12.34m x 2m x 2.2m	5,180 lbs 2 350 kg
Turntable ¹ (Complete) 	11'-4" x 7'-8" x 8'-6" 3.45m x 2.34m x 2.6m	23,810 lbs 10 800 kg	Jib Section ③ 	38'-10" x 6'-7" x 7'-7" 11.84m x 2m x 2.31m	4,760 lbs 2 160 kg
Operator Cab with Platform & Panel 	8'-2" x 6'-9" x 8'-6" 2.5m x 2.06m x 2.6m	3,085 lbs 1 730 kg	Jib Section ④ 	18'-8" x 6'-7" x 6'-3" 5.69m x 2m x 1.91m	2,010 lbs 910 kg
Tower Section (Climbing) (TSK212) 	8'-0" x 9'-10" x 6'-7" 2.44m x 3m x 2.03m	6,170 lbs 2 800 kg	Jib Section ⑤ 	35'-0" x 6'-7" x 6'-11" 10.67m x 2m x 2.1m	4,010 lbs 1 820 kg
Tower Section S35 (TS212) 	19'-5" x 8'-0" x 8'-0" 5.92m x 2.4m x 2.44m	9,300 lbs 4 220 kg	Jib Section ⑥ 	35'-5" x 6'-7" x 6'-4" 10.8m x 2m x 1.93m	3,000 lbs 1 360 kg
Transition Section S60/S35 	19'-5" x 8'-0" x 8'-0" 5.92m x 2.44m x 2.44m	9,920 lbs 4 500 kg	Jib Section ⑦ 	33'-6" x 6'-7" x 6'-3" 10.21m x 2m x 1.91m	2,160 lbs 980 kg
Tower Section S60 (TS213) 	19'-5" x 8'-0" x 8'-0" 5.92m x 2.44m x 2.44m	9,920 lbs 4 500 kg	Jib Section ⑧ 	18'-8" x 6'-7" x 6'-2" 5.69m x 2m x 1.88m	1,760 lbs 800 kg
Counterjib ² 	69'-11" x 9'-2" x 6'-7" 21.31m x 2.8m x 2.01m	26,500 lbs 12 020 kg	Jib Tip ⑨ 	4'-6" x 6'-8" x 4'-6" 1.37m x 2.03m x 1.37m	860 lbs 390 kg
Counterjib Section (Inner) 	31'-10" x 6'-8" x 5'-7" 9.7m x 2.03m x 1.7m	5,070 lbs 2 300 kg	Jib Assembly Part 1 ⁶ for all Jib Assemblies ①②	75'-0" x 6'-7" x 7'-3" 22.86m x 2m x 2.2m	18,960 lbs 8 600 kg
Counterjib Section (Outer) ³ 	38'-1" x 9'-2" x 6'-7" 11.61m x 2.8m x 2.01m	17,500 lbs 7 940 kg	Jib Assembly Part 2 ⁷ ③④⑤⑥⑦⑧⑨ 246-ft (75m)	180'-0" x 6'-8" x 7'-7" 54.86m x 2.03m x 2.31m	20,720 lbs 9 400 kg
Hoist Unit ⁴ (108 hp/76 kW) 	9'-2" x 8'-5" x 5'-7" 2.8m x 2.57m x 1.7m	7,500 lbs 3 400 kg	Jib Assembly Part 2 ⁷ ③④⑤⑥⑦⑨ 230-ft (70m)	163'-0" x 6'-8" x 7'-7" 49.68m x 2.03m x 2.31m	19,180 lbs 8 700 kg
Counterweight Block A 	14'-8" x 0'-6" x 5'-1" 4.47m x 0.15m x 1.55m	6,810 lbs 3 090 kg	Jib Assembly Part 2 ⁷ ③⑤⑥⑦⑨ 218-ft (65m)	145'-0" x 6'-8" x 7'-7" 44.2m x 2.03m x 2.31m	16,530 lbs 7 500 kg
Trolley (Outer) ⁵ (2-part operation) 	7'-4" x 5'-8" x 6'-0" 2.24m x 1.73m x 1.83m	1,760 lbs 800 kg	Jib Assembly Part 2 ⁷ ③④⑤⑥⑨ 197-ft (60m)	129'-0" x 6'-8" x 7'-7" 39.32m x 2.03m x 2.31m	17,200 lbs 7 800 kg
Hook Block (Single) 	2'-9" x 1'-0" x 4'-6" 0.84m x 0.31m x 1.37m	1,190 lbs 540 kg	Jib Assembly Part 2 ⁷ ③⑤⑥⑨ 180-ft (55m)	111'-0" x 6'-8" x 7'-7" 33.83m x 2.03m x 2.31m	14,550 lbs 6 600 kg
Top Climbing Unit (Complete) (TS212) 	29'-3" x 11'-6" x 11'-6" 8.92m x 3.5m x 3.5m	25,000 lbs 11 340 kg	Jib Assembly (Complete) ①②③④⑤⑨ 164-ft (50m)	170'-0" x 6'-8" x 7'-7" 51.82m x 2.03m x 2.31m	33,290 lbs 15 100 kg
Tie-in Collar S35 (TS212) 	12'-2" x 10'-2" x 1'-7" 3.7m x 3.1m x 0.48m	3,200 lbs 1 450 kg	Jib Assembly (Complete) ①②③⑤⑨ 148-ft (45m)	151'-0" x 6'-8" x 7'-7" 46.02m x 2.03m x 2.31m	31,530 lbs 14 300 kg
Jib A-Frame 	21'-7" x 5'-5" x 4'-8" 6.58m x 1.65m x 1.42m	660 lbs 300 kg	Jib Assembly (Complete) ①②③④⑨ 131-ft (40m)	135'-0" x 6'-8" x 7'-7" 41.15m x 2.03m x 2.31m	29,100 lbs 13 200 kg
Jib Section ① 	38'-11" x 6'-7" x 7'-3" 11.86m x 2m x 2.2m	6,660 lbs 3 020 kg	Jib Assembly (Complete) ①②③⑨ 115-ft (35m)	117'-0" x 6'-8" x 7'-7" 35.66m x 2.03m x 2.31m	27,560 lbs 12 500 kg

NOTE! Weights and dimensions are approximate. Scale components before lifting.

¹ Turntable (Complete) includes swing motors, slewing ring, slewing ring support.

² Includes Counterjib Sections #1 & #2, 108 hp (76 kW) hoist unit with frame, electrical panel and handrails. Does not include wire rope.

³ Counterjib Section #2 includes 108 hp (76 kW) hoist unit and handrails. Does not include wire rope. 22mm rope weighs 2 lbs/ft (2.7 kg/m)

⁴ Does not include wire rope. 22mm rope weighs 2 lbs/ft (2.7 kg/m)

⁵ Two-part operation requires a single (outer) trolley. Four-part operation requires two (inner and outer) trolleys. Inner and outer trolley dimensions and weights are the same.

⁶ Jib Assembly Part 1 includes jib sections, pendant cables, jib A-frame, trolley drive unit, trolley wire rope, 2-part trolley (outer) and hook block. If 4-part application is used, weight increases by approx. 1,830 lbs (830 kg) for additional trolley (inner) and hook block.

⁷ Jib Assembly Part 2 includes jib sections and pendant cables.